

# HYDROGEN GAS GENERATOR

## USER'S GUIDE



Shijiazhuang Bondi Technology Co., Ltd

## Preface

Dear customers!

Thank you for choosing to use the hydrogen generator. If you are using this product for the first time, please read the following product instructions and use instructions carefully.

The hydrogen generator use manual describes the composition, function, operation process, precautions and the methods of using the hydrogen generator for pipeline inspection and leakage location of the hydrogen generator. Read carefully and fully understand the use manual before operating or using the hydrogen generator. If you have any questions about the operation and use of the hydrogen generator, you can call our company at any time, and our company will provide you with timely and enthusiastic technical support and service. Thank you for your cooperation!

Please keep the manual properly for reference when necessary. If the manual is lost or damaged, please contact us immediately.

Shijiazhuang Bondi Technology Co., Ltd

Address: No.55 Yunkai Road, Luquan District, Shijiazhuang City, Hebei Province, China.

Zip code: 050200

Phone: 400-8165-077

Email: [bondikj2024@gmail.com](mailto:bondikj2024@gmail.com)

## 1 Product introduction

Hydrogen electrolytic cell uses PEM technology to input the pure water conductivity 5 us / cm into the anode chamber, is supplied to the membrane electrode components, in the anode side reaction of oxygen, hydrogen ions and electrons ( $2H_2O - 4H^+ + 4e^- + O_2$ ) electrons through the external circuit, hydrogen ions ( $H^+$ ) to the cathode through the proton exchange membrane, absorb electrons to form hydrogen ( $4H^+ + 4e^- \rightarrow 2H_2$ ), discharged from the cathode chamber, into the gas-water separator after gas and water separation to generate pure hydrogen gas.

$H_2$  electrolytic cell is composed of electrode components-membrane electrode-sealing components, the core is the membrane electrode,

Our company uses the proton exchange membrane electrode to ensure the safety, stability and high purity of the electrolytic cell output Hydrogen oxygen gas.

## 2 Technical parameters

Technical parameters of the hydrogen generator are shown in Table 2.1

Table 2.1 Technical parameters of the sensor

type	Pure water electrolysis to produce hydrogen
Power Supply Voltage	AC 220V (AC 110V is customized)
applicable temperature	5°C~+50°C
Water quality	Pure water or distilled water with a conductivity of 5us / cm
gen	PEM electric tank

## Water Leak Detector

Power supply of electrolytic cell	DC 15V 30A
Water pump power supply	DC 12V 450MA
pump capacity	1600mL/min $\pm$ 5%
H <sub>2</sub> gas production	1800mL/min
Purified water consumption	Approx. 300mL (8 hours of continuous operation)
weight	850g

### 3. Instrument composition

The product composition of the hydrogen generator is shown in Figure 2.2.

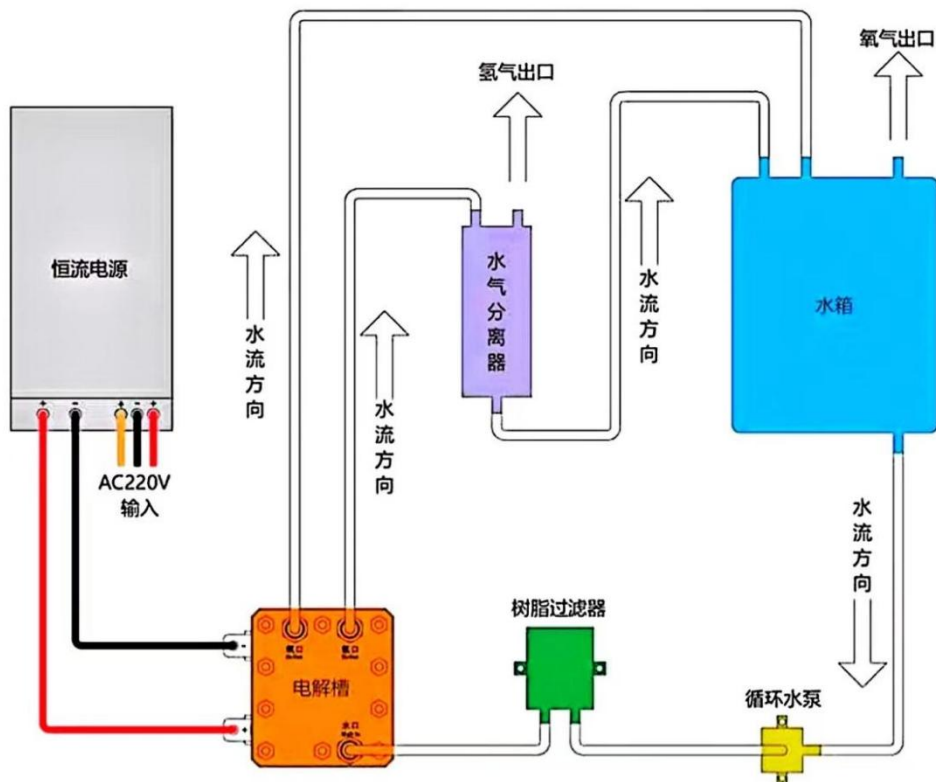

Figure 2.2 Composition of hydrogen generator

### 3.2 Host unit composition

3.2.1 Description of the working interface

Display area and operation function description, as shown in Figure

2.3.

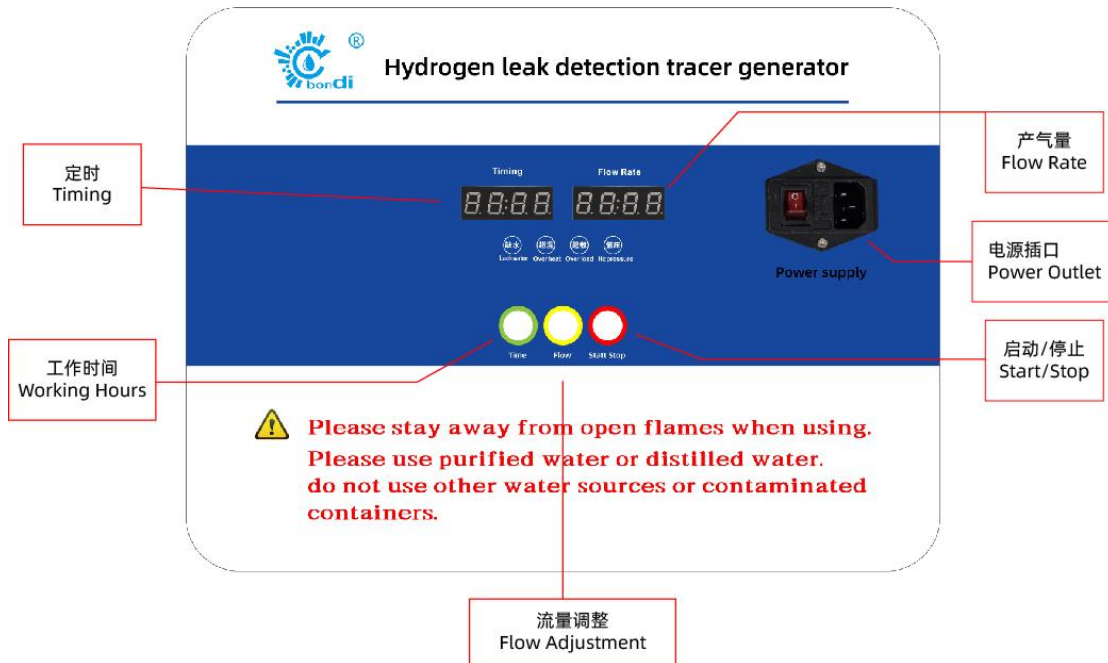

Figure 2.3 Description of the working interface

**Power Supply Switch (Power Supply)**

AC 220V (110V) power supply power supply socket, after connecting the power supply. Turn the power switch on and energize the device, then the device enters the working standby state.

	Check the power supply status after the equipment is energized to prevent abnormalities.
--	--

**Start / stop push button (Start Stop)**

This button is a touch switch, light the switch the device to start working, and click the device to stop working.

After the equipment starts, observe whether the pump is working and whether there is a lot of water and bubbles out of the outlet pipe.



Before starting the equipment, please check whether the water level of the water tank is sufficient, whether the water inlet pipe is put into the water tank and placed at the bottom of the water tank, and whether the water outlet pipe and overflow pipe are placed in the water tank.

**Flow Button (Flow)**

To adjust the gas production. The gas production rate can be adjusted by the cycle press-release. The adjustment range is: 600 mL-900 mL-1200 mL-1800 mL.

**Timing pushbutton (Time)**

Used to adjust the working hours. Working hours can be cycled by cycle press-release. The adjustment range is: 30min-1S-2S-3S-4S-5S-6S.

**Gas production (Flow Rate)**

The LED digital tube displays the current equivalent gas production per minute. The maximum gas production is 1800 mL/min.

**Timing (Timing)**

The LED digital tubes display the number for the remaining time of the current operation. When the time is 00:00, the device will stop working.

**3.2.2 Main interface**

The main interfaces on the host unit are distributed on the left and right sides of the host unit. As shown in Figure 2.4, Figure 2.5.

# Water Leak Detector



Figure 2.4 Main interface



Figure 2.5 Main Interface

### 3.2.3 Installation and connection of the hydrogen gas generator

1. Insert one end of the three blue water pipes into the water inlet, water outlet and overflow outlet respectively, and put the other end of the water pipe into the external water tank.

2. Insert one end of the white pipe into the H<sub>2</sub> gas outlet, and discharge the other end of the H<sub>2</sub> white pipe after starting the equipment.

3. Plug the power cord into the power switch socket.

When connection, the hydrogen generator is shown in Figure 2.6.



Figure 2.6 Installation and connection of the hydrogen gas generator

### 3.3 Check before the use

Please ensure that the following 3 steps are done before using the hydrogen generator to ensure that the inspection equipment reaches the optimal working state when startup.

#### 1. Connecting of equipment components

Check that all connecting pipes are inserted into the jack holes, located correctly, and firmly installed.

#### 2. Check the power supply

Before starting to use the equipment, always check that the power cord is firmly installed, the connected power supply meets the use standards of the equipment, and the power supply is connected normally

#### 3. Check the water level of the water tank

Before using the equipment, always check the external water tank for sufficient water storage. One end of the inlet pipe, outlet pipe and overflow pipe is placed in the water tank, and the inlet pipe is located at the bottom of the water tank to prevent water shortage when using.

#### 4. Check the pump

Check the working condition of the pump, and start the equipment to check whether the working condition of the pump is normal.

#### 5. Put it in place

The placement position of the hydrogen generator host should be 30cm higher than the external water tank.



Keep away from the open flame while using the hydrogen generator.



The circulating water used by the hydrogen generator must be pure water or distilled water.  
The external water tank can not use the contaminated water tank, whether it will cause fatal damage to the PEM electrolytic tank.

#### 4. How to use hydrogen generators in pipeline leak detection

4.1 When the hydrogen generator is used for pipeline leakage detection, the hydrogen outlet of the hydrogen generator needs to be placed at the air inlet of the air compressor (but the hydrogen pipe cannot completely block the compressor inlet), and the hydrogen produced is sucked into the air through the air inlet and compressed and injected into the leakage pipeline to be detected. Hydrogen enters the pipeline and leaks out through the gaps in the soil, cement and asphalt, and we use a gas detector to detect the location of the pipeline leak along the pipeline. When the hydrogen generator is used with an air compressor, the hydrogen content in the air compressor is shown in Table 4.1

Air compressor outlet	Gas production of the Bondi hydrogen generator	Mixture of gas hydrogen content ratio
100L/min	1800ML/min	1.8%
200L/min	1800ML/min	0.9%
600L/min	1800ML/min	0.3%
1800L/min	1800ML/min	0.1%
2650L/min	1800ML/min	0.067%

Table 4.1 Hydrogen content output from air compressors

4.2 Three conditions for hydrogen combustion or explosion are met:

1. Hydrogen concentration reaches the flammable range: The

flammable range of hydrogen in the air is 4%-75%, and only in this concentration range will the explosion reaction occur. If the hydrogen concentration is less than 4%, the hydrogen cannot be burned; If the hydrogen concentration is higher than 75%, the mixture of hydrogen and air is too oxygen-rich and burns too fast, which can also cause an explosion.

2. The flammability range of oxygen in air is: 5% to 21%, and only in this concentration range can combustion be supported. If the oxygen concentration is less than 5%, hydrogen cannot be burned; If the oxygen concentration is higher than 21%, the mixture of hydrogen and air is too oxygen-poor and burns too slowly, which can also cause an explosion.

3. Sufficient energy to initiate the reaction: This energy can come from various factors such as sparks, static electricity, high temperature, etc. If there is not enough energy to initiate the reaction, there will be no explosion even if both the hydrogen concentration and the oxygen concentration reach the flammable range.

## 5. Troubleshooting

Fault phenomenon	cause	Exclusions
The outlet pipe does not produce water or the amount of water is small	The water pump is not working	Check the supply voltage or pump power cord
There is no large amount of water and a lot of bubbles in the outlet pipe	The electrolyzer is not working	Check the supply voltage and the power supply to the electrolyzer
There is a large amount of water discharged from the hydrogen outlet	compressor inlet is too large or the overflow pipe of the air-water separator is too high, and the separated water cannot be discharged	The distance between the hydrogen outlet and the air compressor inlet is too close to the air compressor inlet to increase the distance between the two. Take the overflow pipe out of the tank and place it lower than the generator
There is no gas output from hydrogen exports	The electrolyzer is not working	Check that the electrolyzer and water pump are operating properly