

C-11 Indoor Water Leakage Detector

User Manual



Shijiazhuang Bondi Technology Co., LTD

Preface

Dear customers!

Thank you for choosing to use the C-11 pipeline leak detector. If you are using this product for the first time, please read the following product instructions and use instructions carefully.

The C-11 operation manual details the composition, function, operation process, precautions of the underground pipeline leakage detector, and the methods of pipeline inspection and leakage positioning by using the C-11 pipeline leakage detector. Please carefully read and fully understand the use manual before operating or using the C-11 pipe leak detector. If you have any questions about the operation and use of C-11, you can call our company at any time, and our company will provide you with timely and sincere technical support and service. Thank you for your cooperation!

Please keep the manual properly for reference when necessary. If the manual is lost or damaged, please contact us immediately.

Shijiazhuang Bondi Technology Co., LTD

Address: No.55, Yunlu Road, Economic Development Zone, Luquan District, Shijiazhuang City, Hebei Province

Postcode: 050000

Tel.: 400-8165-077

E-mail :bondikj2024@gmail.com

1 Technical parameters

| | |
|-----------------------------|--|
| Enlargement factor | 120db |
| Frequency range | 200-4000Hz |
| Power pack | Lithium battery is 8.4V 2000Mah, equipped with a charger |
| Operating temperature range | -20°C~+55°C |
| Continuous working hours | ≥36 hours |
| Display screen | LED Nixie light |
| Rejector | The 4 lanes are switchable |
| Depth of investigation | 1m |
| Size | 184mm×138mm×80mm |

Table 1.3 Technical parameters of the headset

| | |
|-----------------------|-------------------------------------|
| The voice mode | surround sound |
| Operational principle | Fully enclosed listening headphones |
| The horn diameter | 40mm |
| Response Frequency | 200Hz-5000KHz |
| Impedance | 32Ω |

2 Instrument composition

C-11 Pipeline leakage detector consists of host unit and software system.

The C-11 pipeline leak detector host unit includes a sensor and control handle for obtaining a leak signal, a host for leak signal processing and information display, and a high-fidelity headset for listening to identify the leakage status. When the host system inspects or locations the leakage, the control status information of the

Water Leak Detector

leakage detection is displayed in the way of sound and digital tube through the LED digital tube and headset on the host panel.

2.1 Product composition

The product composition of C-11 pipeline leak detector is shown in Table

2.1. Table 2.1, components of the detector

| | | |
|---|---|---|
| Host unit 1 piece | 1 piece of the multi-function sensor | One indoor sensor |
|  |  |  |
| One handle | One piece of headphones | One charger |
|  |  |  |
| Shoulder belt | One instrument box | |
|  |  | |

2.2 Host unit composition

The host unit unit is the main component of the detector, including the host unit (including power supply, main interface, LED digital tube, etc.), control handle and sensor, headset, battery pack and charger. This section will detail the distribution functions, specifications and performance, connection mode, etc. of the host unit composition.

Water Leak Detector

2.2.1 Host machine



Figure LED digital tube displayLED

The digital tube is used to display the size of the leak sound, filter control information, and host status information.

The leakage sound intensity is related to the value of the LED digital tube. The higher the value displayed by the LED digital tube, the greater the leakage sound intensity.

2.2.2 Operation panel

The operating panels are distributed around the LED digital tubes, as shown in Figure Figure 2.2.



Figure 2.2 Operating interface

Water Leak Detector

Power switch and volume control (POWER OFF)

Used for power switch and volume adjustment.

| | |
|---|--|
|  | Check the power supply status after startup/shutdown to prevent abnormality. |
|---|--|

Filter adjustment (SOUNDFILTRE)

According to the actual requirements of the user, in order to meet the leakage detection needs of different materials / pipe diameter pipes and different working sections (buried media) (commonly used 4 channels).

Note: The filter adjustment is adjusted by the operator according to the field situation.

LED digital tube and pointer table

The LED digital tube has the same function as the pointer table to indicate the intensity of the detected leaking sound signal.

2.2.3 Control handle

The control handle assembly is used to connect the sensor to the host component, as shown in Figure 2.3.



Figure 2.3, Control handle

The operator releases the mute switch to connect the headset signal channel when the headset output leaks the vibration audio signal; when the handle mute switch is pressed. At this time, the headset is silent, with no audio signal output.

| | |
|---|---|
|  | In the process of moving the sensor, press the mute switch to cut off the signal to the headset to prevent excessive sound intensity impact on the operator's hearing and cause hearing damage. |
|---|---|

Water Leak Detector

| | |
|---|--|
|  | <p>The handle switch has electronic circuit and mechanical structure, do not dismantle without authorization. Otherwise, it may cause the functional damage of the handle.</p> <p>The handle switch is not waterproof and dustproof, please use it in a dry and clean environment. Otherwise, it may cause the handle function reliability to decline or damage.</p> |
|---|--|

2.2.4 Sensors

The sensor is placed on the surface of the measured pipeline and buried pipe medium to obtain the vibration signal of pipeline leakage propagation, as shown in Figure 2.4.



Figure 2.4 Sensor

The C-11 is equipped with two sensors, which are used in different scenarios. The probe sensor has high sensitivity and should be the first choice when using it. It is suitable for flat ground or wall, and should not be used on water. The multi-function sensor can be used on uneven ground or slightly wet ground.

2.2.5 Headphones

The headset is used to output the leakage and vibration audio signal of the host machine. The C-11 is configured with high-fidelity stereo headphones, as shown in Figure 2.5.



Figure 2.5 Headphone

Headphone speakers are left and right. For some people, the left and right ears are not sensitive to sound, so please wear the left (L) right (R) marked on the headset. Can also according to the actual situation, change the order of the left and right speakers, to better complete the sound detection.

| | |
|---|--|
|  | <p>The dynamic range of the actual leaky vibratory audio signal is large. Sometimes the output audio signal intensity is very large, so when wearing the earphone for sound detection, special attention should be paid to the ability to adjust the volume (by adjusting the "sensitivity" knob), so as not to damage the ears of the testing personnel or can not hear the sound around to cause danger.</p> |
|---|--|

2 2.6 Battery pack and the charger

The C-11 pipeline leak detector uses a high performance, large capacity rechargeable lithium ion battery module and is equipped with a DC 8.4V charger as shown in Figure 2.6



Figure 2.6 ChargerC-11

The pipeline leak detector is equipped with a special automatic charging adapter. The charger needs to be plugged into the DC charging port for charging. When charging, the charger indicator light is red, and the indicator light is green

when the battery is full.



It is recommended not to turn on the power of the main engine switch during charging to prevent damage to the instrument or to extend the charging time.

3 by using a C-11 tester

3.1 The installed C-11 pipeline leakage detector is shown in Figure 3.1 3.2.



图 3.1



Figure 3.2 C-11 Installation and connection of pipeline leakage detector

3.2 Pre-use inspection

Please ensure that the following 3 inspection steps are done before using the C-11 pipeline leak detector to ensure that the detector reaches the optimal working state during the leak detection.

1. Check the instrument components

Check whether the host machine and accessories are complete, whether the sensor connection is reliable; whether the shoulder strap is clean, firm and reliable.

2. Check the operation of the instrument

Connect the sensor and headset to the host and check as follows:

- (1) Turn on the power switch, and the LED digital display will show numbers.
- (2) Put on the headphones and press or release the mute switch on the handle to check if there is any sound in the headphones.
- (3) Check if there are any changes in the values of the LED digital tube and pointer meter.

If you find any problems during the inspection, please check the "5. Troubleshooting" later in this manual. If there are still problems that cannot be solved, please contact our company.

4 Detection method of pressure pipe leakage

Sandoma, damage, cracks and other injuries occur in the buried pressure pipeline. Due to the pressure inside the underground pipeline, there is a pressure difference inside and outside the pipeline, which leads to the outward injection of water flow. In this process, the jet water and the damage cause friction and cause vibration in the damage, the pressure jet water shocks the buried pipe medium resulting in the vibration, the leakage water flow outside the pipeline to produce the turbulent sound is the general sense of the sound of leakage.

Despite the help of advanced detector, including C-11, due to the leakage sound intensity and spectrum distribution (tone) will be affected by pipe pressure, buried media, pipe material, pipe diameter and other factors, so in the actual leakage point, also need to detect the rich practical experience to accurately determine whether the leakage vibration signal.

4.1 Sound and characteristics of pipeline leakage

4.1.1 Leaking sound components

Water Leak Detector

The composition of the leaking sound mainly consists of the following four parts:

(1)The sound of the pipe breaking and the pressurized water flowing;

(2)Vibration sound at the broken pipe;

(3)The jet water flow shocks the buried pipe medium to produce the shock and vibration sound;

(4)The sound of jet water spinning around the damage.

The above (1) and (2) sound sources propagate along the pipeline axis. Therefore, in the actual leak detection process, if conditions permit, find the pipe above the ground, and the sensor is placed on the measured pipe. Such as the pipe itself, valves, fire hydrants, etc.

The above (3) and (4) sound sources propagate outward in a spherical wave vibration in the buried tube medium. Therefore, in the actual leak detection process, the general direction of the pipeline buried in the medium is found. Place the sensor on the surface of the buried pipe medium directly above the pipe direction. And as perpendicular to the wavefront.

4.1.2 Leaking sound, frequency characteristics

The leakage vibration signal is composed of multiple sound source vibration signals with complex frequency components. It is generally believed that the spectrum range of the leakage vibration signal is distributed in the range of 20Hz-5000Hz, and the mainstream spectrum distribution of the common pipeline leakage is about 200Hz-2000Hz.

The frequency of the leakage sound output of the headset is affected by the pipe material. Under the same pipe diameter conditions, metal pipes have more high-frequency leakage sound components. According to different materials such as cast iron / steel pipe / copper pipe, the frequency spectrum range of water leakage sound is about (400Hz~600Hz) - (1200Hz~3000Hz). Plastic or PVC pipes have more low-frequency leakage components, and the spectrum range is about (100Hz~400Hz) - (600Hz~800Hz).

The frequency of the leakage sound of the headset is affected by the buried media of the pipe. Generally speaking, hard and solid media (such as concrete) is conducive to sound transmission, high frequency composition. Loose medium with gaps (such as sand, mud, grass, etc.) on the absorption of sound energy is obvious, the sound is low, the volume is low.

Water Leak Detector

4.1.3 The intensity of the leaking sound

The intensity of the leaking sound can be simply understood as the volume size of the leaked sound. The leakage sound intensity of the earphone output is affected by many factors, such as the leakage source, water supply pressure, pipe diameter, buried pipe medium, buried pipe depth and so on.

Generally speaking, the sound below 20 decibels is quiet; 20-40 decibels is quiet. A sound of 40-60 decibels is normal. Above 60-70 decibels is noisy, and the sound above 80 decibels begins to damage the hearing nerve.

The C-11 is used to adjust the size of the headset output volume. According to the actual situation, adjust the volume of the headset to the sound more comfortable range of the leak detector (vary from person to person).

4.1.4 Check along the pipeline

When there is sufficient information to indicate the direction of the detected pipeline, the leakage detection and positioning. The method of testing along the line is shown in Figure 4.1.

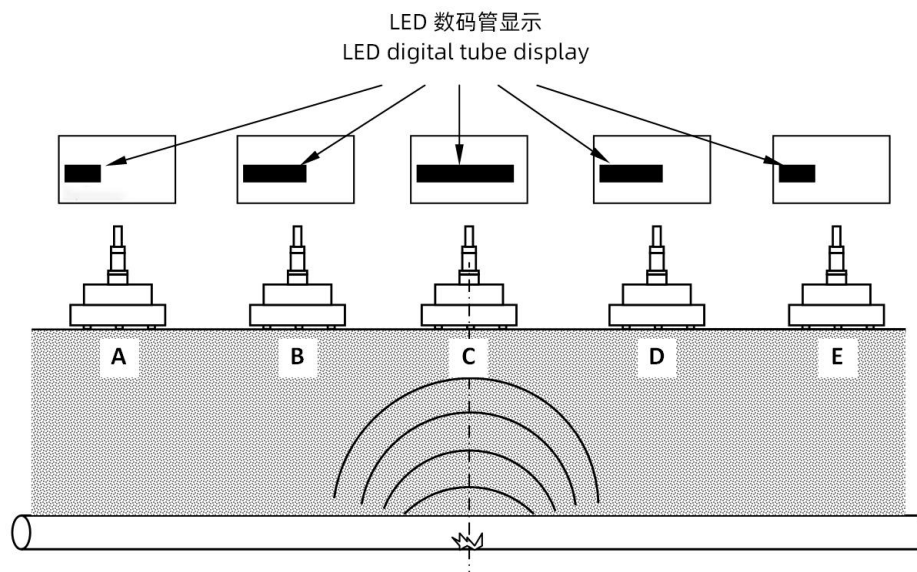

Figure 4.1 Change of leakage sound size during detection along the pipeline

According to the pipeline direction, the detection starts from any point on the ground above the pipeline (such as point A shown in Figure 4.1, middle). The detection method and process are as follows:

- (1) Place the sensor on the ground directly above the line, for example, at point A.
- (2) Press the handle to mute the control switch. If there is a leak in the pipe,

Water Leak Detector

there will be a significant continuous leak sound in the headset. If the pipe does not leak, the sound in the headset is small, or only random bursts in the surrounding environment.

(3) Listen to sound detection. Relax the connecting line between the sensor and the handle, keep the sensor fixed and stable, and select the relatively calm moment around. In addition to carefully identifying the size and audio of the leaking sound, but also observe the change of the horizontal column bar in the LED and remember the minimum value detected at that point.

(4) Release the handle and move along the line direction of 0.2~1.0 m to other points (B, C, D, E) repeat (1) ~ (3).

(5) Multiple detection times around the detection point with the largest minimum value among multiple detection points (point C in the figure) to accurately achieve leakage positioning.

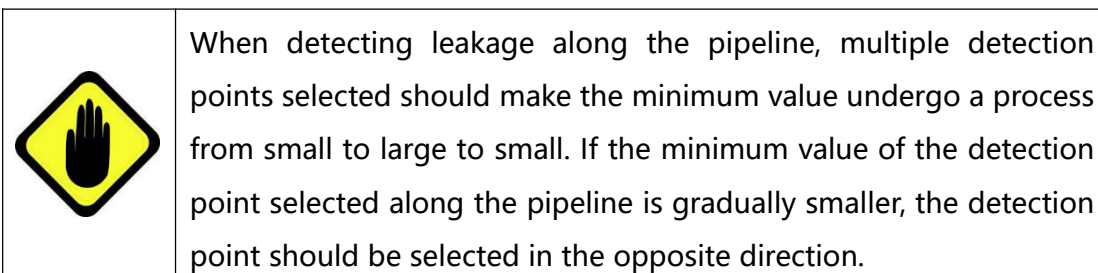

4.2 1 Locate the leak point

In the actual leakage detection, if the pipeline direction is not clear or the pipeline direction is deviated from the data, the following two-step method can be used to achieve leakage location, as shown in Figure 4.2.

(1) Leak detection starts above the line that can be identified. For example, in Figure 4.2, the detection starts at point A. Point C is gradually detected along the straight line A-B-C starting from point A, and the leakage listening and minimum will go through a process from small to large and from large to small. The detection point with the largest minimum value in this process is determined as the starting point for the next test, as shown in Figure 4.2 at point B.

(2) Starting in point B, perpendicular to the AC, start the second step of detection along B-D-E. In the second step of detection, the detection point with the largest or the smallest leakage listening value was determined as the leakage point.

Point D in Figure Figure 4.2.

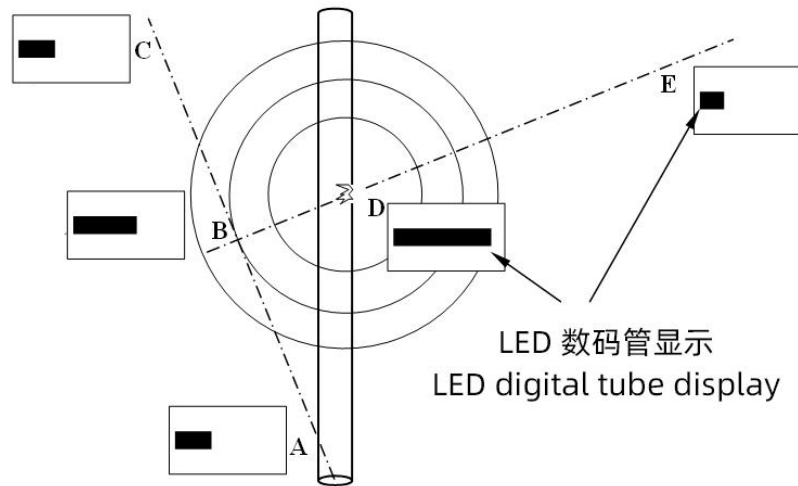

Figure 4.2 A two-step method

4.2 2 Effect of dispersion on leakage localization

The vibration signal generated by leakage is transmitted to the ground through various media such as pipe and buried layer, and is detected and identified by the sensor to realize leakage detection. When the leakage vibration signal passes through the buried layer of different media, some signal components are absorbed and some are attenuated. Compared with the leakage signal, the vibration signal transmitted to the ground has a large change in the loudness and the sound tone, which is the dispersion phenomenon. Frequency dispersion is an objective physical phenomenon, and corresponding countermeasures need to be taken for this detection.

In view of the dispersion phenomenon, the following points should be paid attention to in the leakage detection.

First, before leakage detection, carefully understand the media condition of the ground to determine whether the pipeline buried layer is soft or tight. Generally speaking, the decay and absorption of leakage high frequency sound of soft buried layer is obvious, and the solid buried layer is conducive to the transmission of high frequency signal. The above judgment helps in selecting an appropriate band-pass filtering frequency band before detection.

Secondly, in listening detection, in addition to paying attention to the loudness of the sound, but also pay special attention to the change of sound tone. If the tone changes significantly in a smaller range, further testing should be performed to determine whether it is leakage or water, or buried mutation.

Water Leak Detector

Due to the complex situation of media such as buried layer, a slightly moving sensor may appear near the point of suspicious leakage, and the leakage sound or minimum value will suddenly become larger / small. This may also result from the dispersion. From another perspective, when the leakage sound or minimum level bar shows the maximum value in the latest time, the sensor is not necessarily directly above the leakage point, depending on the ground, buried layer, etc.

5. Trouble answer

| fault phenomenon | reason | Exclusion measures |
|--|---|--|
| The LED digital tubes do not display numerical values | Low battery capacity | Charge the instrument |
| The headset does not sound, and there is no value display | Sensor, handle, and host connections are unreliable | Check the connector for a reliable connection |
| Some value show that the headphones can not hear the sound | The headset is not reliable to the host | Check the connector for a reliable connection |
| The headphones are howling | The sensors and headphones are too close | Do not keep the headset close to the sensor, and lower the volume of the headset appropriately |
| After a very short time since Move the shutdown | The battery voltage is insufficient | The battery is charged or replaced promptly |